

HEC

For the harshest environmental conditions



HEC HARSH ENVIRONMENT CONNECTOR

Designed for use in the harshest environments and outdoor environments, such as extreme weather conditions, extreme temperatures, dust, humidity, liquids or vibrations.

The HEC series is part of our extensive range of power connectors, making it suitable for virtually any low and high voltage application. This enables versatility, which is also reflected in the possible areas of application. These include agricultural and construction machinery, chemical plants/process engineering, mining and surface mining, mechanical engineering and non-contact areas in the food industry.

Connectors for harsh environments of the HEC Series 696 are available as cable connectors and rectangular panel mount versions with or without integrated protective hose fitting, which can protect cables up to IP67 and in mated condition up to IP69K. The connectors are UV-resistant and have VDE and UL approval. The high mechanical load capacity of the products is confirmed by more than 500 mating cycles for the 12-pole version and more than 1000 mating cycles for the 5- and 8-pole versions.

ADVANTAGES

- Bayonet quick locking for a time saving connection.
- Compact design: power supply for your system or drive unit even in confined spaces.
- Degree of protection IP68 and IP69K for permanent submersion and high-pressure cleaning.
- Hybrid version for simultaneous power supply and signal transmission with only one plug-in.
- Good resistance to chemicals and corrosion for use in the non-contact food industry and process engineering.

FEATURES

- Designed for outdoor use
- Bayonet locking
- 5(4+PE)-, 8(4 + 3+PE)- and 12-pole
- Degree of protection IP68/IP69K
- Crimp termination
- Diameter cable parts 36 mm, panel mount parts 40 mm
- VDE and UL approval
- Extensive accessories





SECTORS AND FIELDS OF APPLICATION

- Mining and surface mining
- Chemical and process engineering
- Non-contact food industry
- Agricultural and construction machinery
- Mechanical engineering and materials handling

PRODUCT OVERVIEW

Power
Bayonet HEC · 696 Series

- Bayonet locking system
- 5, 8 and 12 contacts
- Degree of protection IP68 / IP69K
- Crimp termination
- Diameter cable connectors 36 mm, Panel mount connectors 40 x 40 mm
- Protective hose fitting
- Panel mount connectors with hinged cover
- Sealing Kit
- VDE-, UL-approval
- Designed for harsh environments

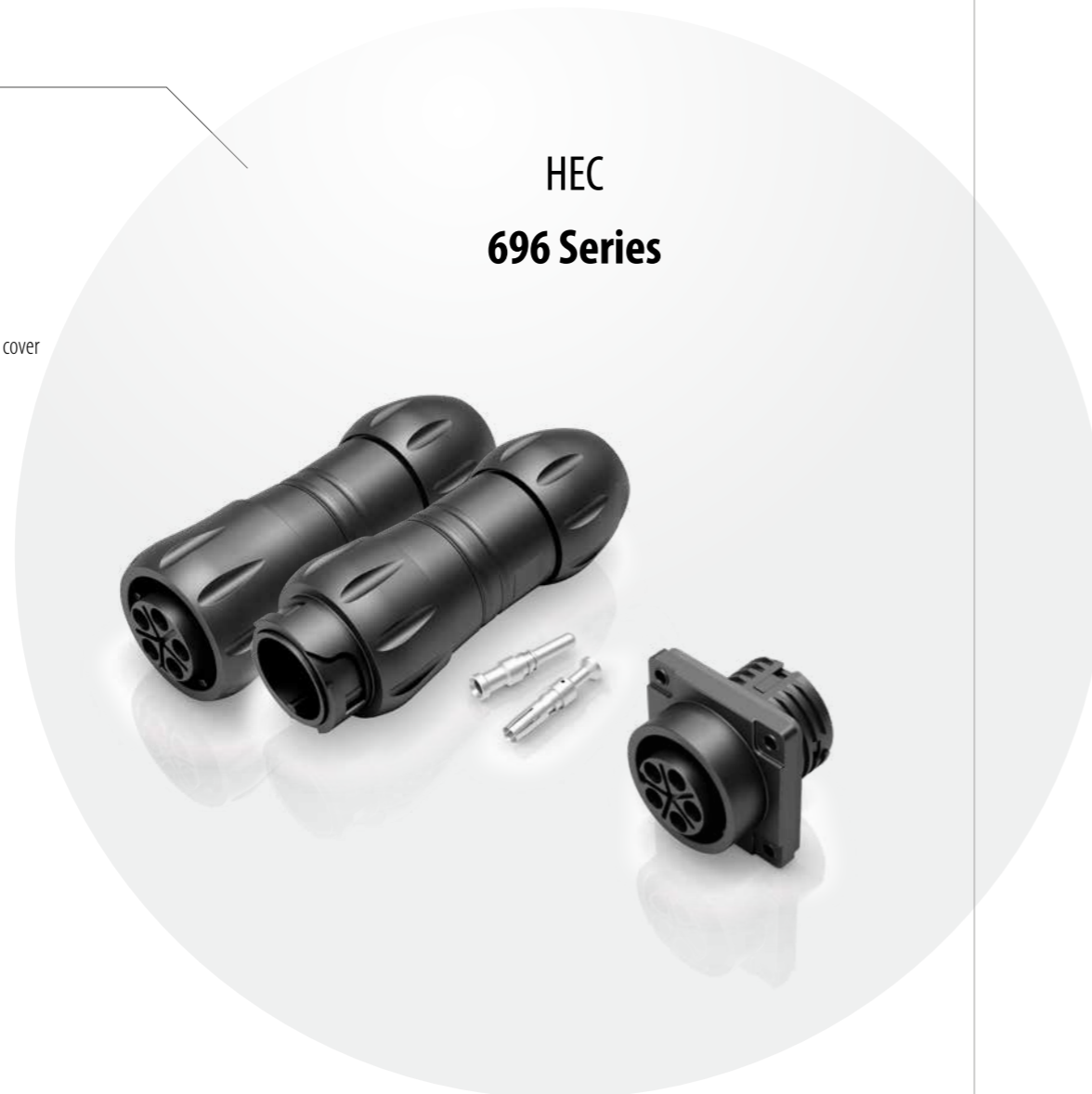

- Compact design: Power supply for your system or drive unit even in confined spaces.
- Hybrid design for simultaneous power supply and signal transmission with only one plug-in.
- Good chemical and corrosion resistance for use in the non-contact food industry and process engineering.



CONTENTS

Range	Series	Contacts	Degree of protection
Connectors for the harshest environmental conditions			
HEC	696	4+PE, 4 + 3+PE, 12	IP68 / IP69K

Male cable connector

Male cable connector, protective hose fitting



Crimp and strip contacts see page 17/18

Crimp and strip contacts see page 17/18

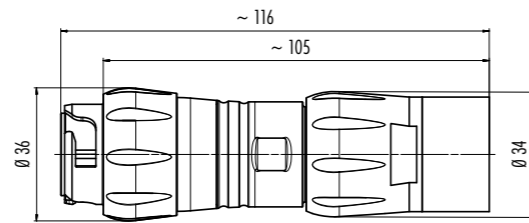
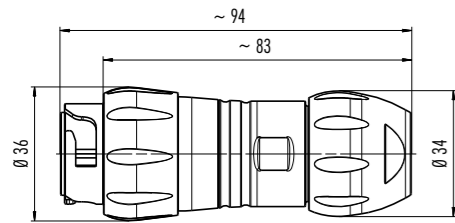

Contacts	Cable outlet	Ordering-No.
4+PE	7–17 mm	99 6489 000 05
4 + 3+PE	7–17 mm	99 6501 000 08
12	7–13 mm	99 6517 000 12

Contacts	Cable outlet	Ordering-No.
4+PE	7–17 mm	99 6489 100 05
4 + 3+PE	7–17 mm	99 6501 100 08
12	7–13 mm	99 6517 100 12

Number of contacts	4+PE	8 (4 + 3+PE)	12
Connector locking system	bayonet		
Termination	crimp		
Wire gauge	2.5–6.0 mm ² (AWG 14–10)	0.14–2.5 mm ² (AWG 26–14)	0.14–0.75 mm ² (AWG 26–18)
Cable outlet	7–17 mm		7–13 mm
Degree of protection	IP68, IP69K		
Mechanical operation	> 1000 mating cycles		> 500 mating cycles
Upper temperature	+ 100 °C		
Lower temperature	– 40 °C		
Rated voltage	600 V	60 V Signal, 400 V Power	250 V
Rated impulse voltage	6000 V	1000 V Signal, 5000 V Power	4000 V
Pollution degree	3		
Overvoltage categorie	III		
Material group	I		
Rated current (40 °C)	32 A ¹⁾	3 A Signal, 25 A Power (20 A UL)	5 A
Material of contact	—		
Contact plating	See crimp contacts page 17/18.		
Material of contact body	PA		
Material of housing	PA		
Material of locking	PA		

¹⁾ 30 A acc. to UL 2238, 22 A acc. to C 22.2

Female cable connector

Female cable connector, protective hose fitting



Crimp and strip contacts see page 17/18

Crimp and strip contacts see page 17/18

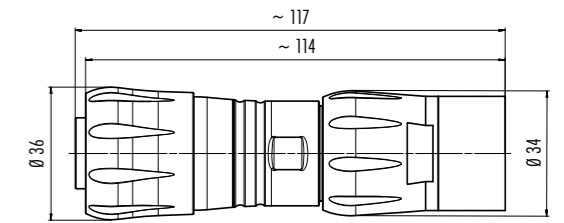
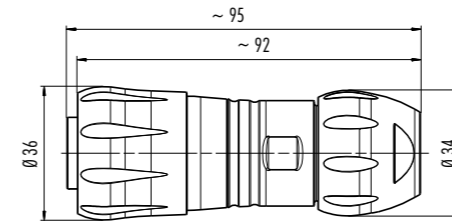

Contacts	Cable outlet	Ordering-No.
4+PE	7–17 mm	99 6490 000 05
4 + 3+PE	7–17 mm	99 6502 000 08
12	7–13 mm	99 6518 000 12

Contacts	Cable outlet	Ordering-No.
4+PE	7–17 mm	99 6490 100 05
4 + 3+PE	7–17 mm	99 6502 100 08
12	7–13 mm	99 6518 100 12

Number of contacts	4+PE	8 (4 + 3+PE)	12
Connector locking system	bayonet		
Termination	crimp		
Wire gauge	2.5–6.0 mm ² (AWG 14–10)	0.14–2.5 mm ² (AWG 26–14)	0.14–0.75 mm ² (AWG 26–18)
Cable outlet	7–17 mm		7–13 mm
Degree of protection	IP68, IP69K		
Mechanical operation	> 1000 mating cycles		> 500 mating cycles
Upper temperature	+ 100 °C		
Lower temperature	– 40 °C		
Rated voltage	600 V	60 V Signal, 400 V Power	250 V
Rated impulse voltage	6000 V	1000 V Signal, 5000 V Power	4000 V
Pollution degree	3		
Overvoltage categorie	III		
Material group	I		
Rated current (40 °C)	32 A ¹⁾	3 A Signal, 25 A Power (20 A UL)	5 A
Material of contact	—		
Contact plating	See crimp contacts page 17/18.		
Material of contact body	PA		
Material of housing	PA		
Material of locking	PA		

¹⁾ 30 A acc. to UL 2238, 22 A acc. to C 22.2

Male panel mount connector

Male panel mount connector, protective hose fitting



Crimp and strip contacts see page 17/18

Crimp and strip contacts see page 17/18

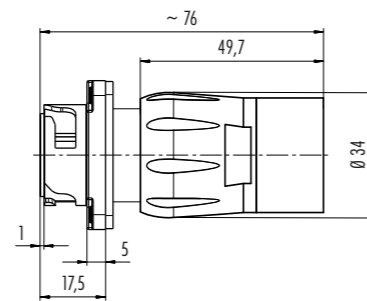
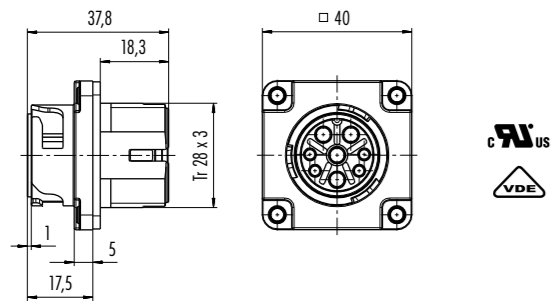

Contacts	Ordering-No.
4+PE	09 6491 000 05
4 + 3+PE	09 6503 000 08
12	09 6519 000 12

Contacts	Ordering-No.
4+PE	09 6491 100 05
4 + 3+PE	09 6503 100 08
12	09 6519 100 12

Number of contacts	4+PE	8 (4 + 3+PE)	12
Connector locking system	bayonet		
Termination	crimp		
Wire gauge	2.5–6.0 mm ² (AWG 14–10)	0.14–2.5 mm ² (AWG 26–14)	0.14–0.75 mm ² (AWG 26–18)
Cable outlet	—		
Degree of protection	IP68, IP69K		
Mechanical operation	> 1000 mating cycles		> 500 mating cycles
Upper temperature	+ 100 °C		
Lower temperature	– 40 °C		
Rated voltage	600 V	60 V Signal, 400 V Power	250 V
Rated impulse voltage	6000 V	1000 V Signal, 5000 V Power	4000 V
Pollution degree	3		
Overvoltage categorie	III		
Material group	I		
Rated current (40 °C)	32 A ¹⁾	3 A Signal, 25 A Power (20 A UL)	5 A
Material of contact	—		
Contact plating	See crimp contacts page 17/18.		
Material of contact body	PA		
Material of housing	PA		
Material of locking	—		

¹⁾ 30 A acc. to UL 2238, 22 A acc. to C 22.2

Female panel mount connector

Female panel mount connector, protective hose fitting

Female panel mount connector, hinged cover



Crimp and strip contacts see page 17/18

Crimp and strip contacts see page 17/18

Crimp and strip contacts see page 17/18

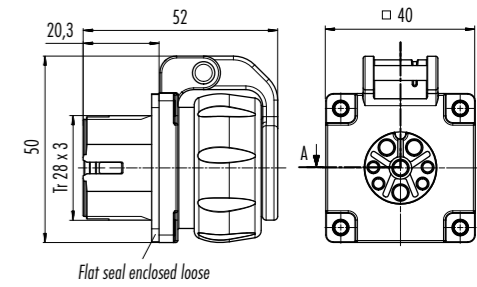
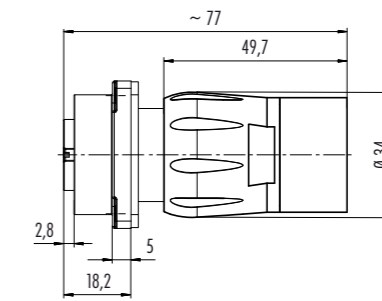
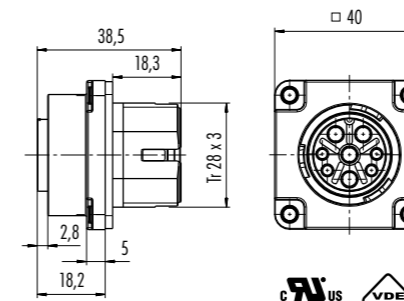

Contacts	Ordering-No.
4+PE	09 6492 000 05
4 + 3+PE	09 6504 000 08
12	09 6520 000 12

Contacts	Ordering-No.
4+PE	09 6492 100 05
4 + 3+PE	09 6504 100 08
12	09 6520 100 12

Contacts	Ordering-No.
4+PE	09 6492 200 05
4 + 3+PE	09 6504 200 08
12	09 6520 200 12

Number of contacts	4+PE	8 (4 + 3+PE)	12
Connector locking system	bayonet		
Termination	crimp		
Wire gauge	2.5–6.0 mm ² (AWG 14–10)	0.14–2.5 mm ² (AWG 26–14)	0.14–0.75 mm ² (AWG 26–18)
Cable outlet	—		
Degree of protection	IP68, IP69K		
Mechanical operation	> 1000 mating cycles		> 500 mating cycles
Upper temperature	+ 100 °C		
Lower temperature	– 40 °C		
Rated voltage	600 V	60 V Signal, 400 V Power	250 V
Rated impulse voltage	6000 V	1000 V Signal, 5000 V Power	4000 V
Pollution degree	3		
Overvoltage categorie	III		
Material group	I		
Rated current (40 °C)	32 A ¹⁾	3 A Signal, 25 A Power (20 A UL)	5 A
Material of contact	—		
Contact plating	See crimp contacts page 17/18.		
Material of contact body	PA		
Material of housing	PA		
Material of locking	—		

¹⁾ 30 A acc. to UL 2238, 22 A acc. to C 22.2

Cable connectors 5 and 8 contacts

- Strip to L = X mm length and take off cable jacket.
- Bead pressing screw, pinch ring, seal and distance sleeve to cable.
- Strip insulation of the single wires (length Y mm).
- Crimp contacts to single wires.*
- Press crimped contacts into contact carrier until they snap into place. Then push the carrier into the connector sleeve to block.
- Put locking unit to the thread of the connector sleeve and screw it towards the direction marked with an arrow until it is tight.
- Push sealing ring into the pinch ring to block and fix both by screwing the pressing screw towards the connector sleeve. (recommended torque 2.5 Nm)

Contacts	contact-Ø	length X	length Y
8	Ø 1.6 mm	45 mm	8 mm
8	Ø 2.5 mm	45 mm	8 mm
5	Ø 3.6 mm	50 mm	12 mm

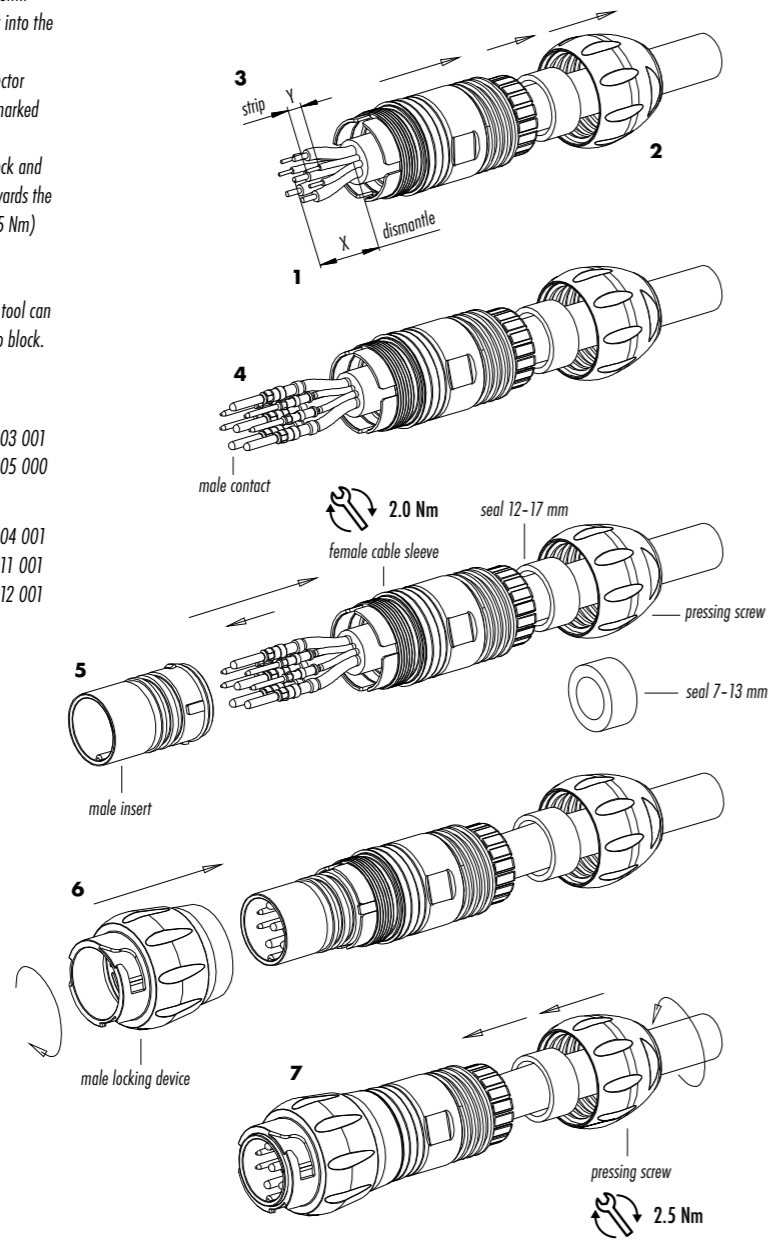

Extracting the contacts:

As the contacts are full floating the extraction tool can be inserted with slight pendular movements to block. Afterwards press the extraction button.

* Crimping tool

Ordering-No.	0.14 - 4 mm ²	66 0003 001
Ordering-No.	1.5 - 6 mm ²	66 0005 000

Extraction tool for contacts

Ordering-No.	Ø 1.6 mm	66 0004 001
Ordering-No.	Ø 2.5 mm	66 0011 001
Ordering-No.	Ø 3.6 mm	66 0012 001

Cable connectors 12 contacts

- Strip to L = 50 mm length and take off cable jacket.
- Bead pressing screw, pinch ring, seal and distance sleeve to cable.
- Strip insulation of the single wires to L = 3.5 mm.
- Crimp contacts to single wires.*
- Press crimped contacts into contact carrier until they snap into place. Then push the carrier into the connector sleeve to block.

Attention! Bear in mind the positioning of the contacts in relation to the housing. The positioning of the contacts is stamped on the contact carrier.

- Put locking unit to the thread of the connector sleeve and screw it with slight pressure towards the direction marked with an arrow until it stops. (recommended torque 0.8 Nm)
- Push sealing ring into the pinch ring to block and fix both by screwing the pressing screw towards the connector sleeve. (recommended torque 2.5 Nm)

Extracting the contacts:

As the contacts are full floating the extraction tool can be inserted with slight pendular movements to block. Afterwards press the extraction button.

* Crimping tool for single contacts
Ordering-No. 66 0001 014 100

Crimping tool for strip contacts
Ordering-No. 67 0001 014 100

Extraction tool for contacts
Ordering-No. 07 0090 000

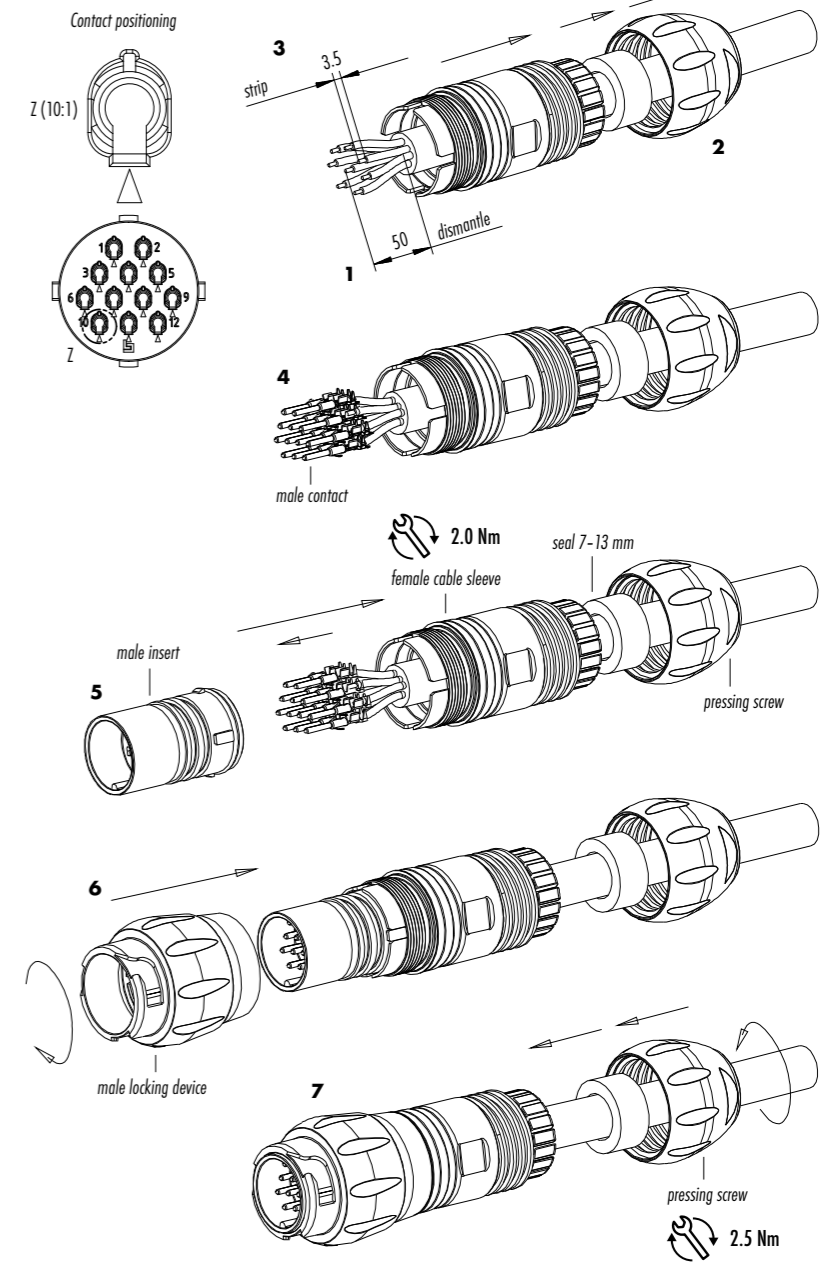

Component part drawing

Cable connectors

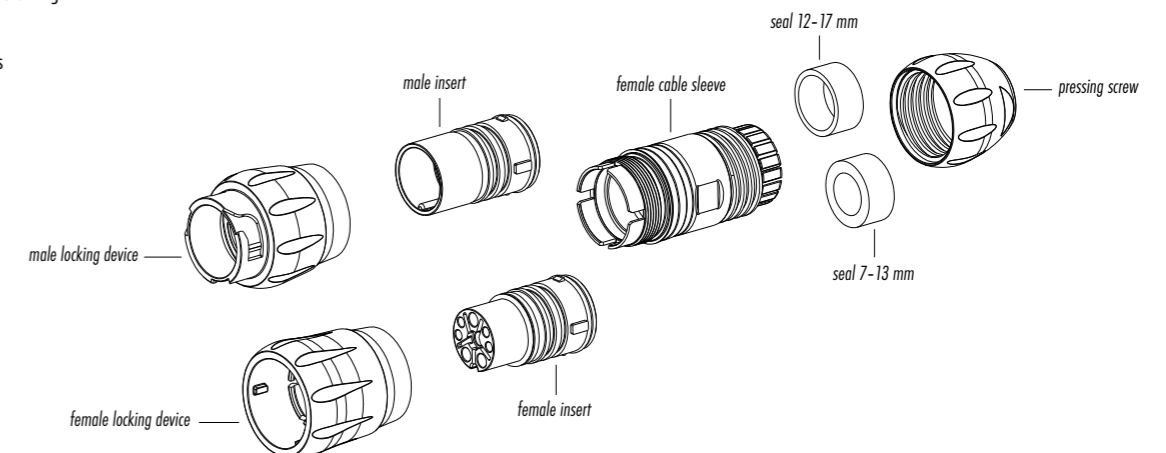

Assembly instruction

Panel mount connectors 5 and 8 contacts

1. Strip single wires to L = 7 mm.
2. Crimp contacts to wires.*
3. Press crimped contacts into contact carrier until they snap into place.
- 3.1. Alternatively when using the single wire seal: **
Pierce through the needed sections of the single wire sealings with a pointed device or tool and then raise them over the contacts.
Then press contacts into the contact carrier, lay the single wire sealings flat onto the contact carrier, press pressure ring to stop and finally fix it with the pressing screw.
4. Push the pressing screw over the bundle of single wires and fix it afterwards by screwing. (recommended torque 1.0 Nm)

Wire-Ø	8 contacts		5 contacts
	Power	Signal	Power
min.	Ø 2.6 mm	Ø 1.7 mm	Ø 3.7 mm
max.	Ø 3.9 mm	Ø 2.7 mm	Ø 4.9 mm

Extracting the contacts:

As the contacts are full floating the extraction tool can be inserted with slight pendular movements to block. Afterwards press the extraction button.

- * Crimping tool
- | | | |
|--------------|--------------------------|-------------|
| Ordering-No. | 0.14 - 4 mm ² | 66 0003 001 |
| Ordering-No. | 1.5 - 6 mm ² | 66 0005 000 |
- Extraction tool for contacts
- | | | |
|--------------|----------|-------------|
| Ordering-No. | Ø 1.6 mm | 66 0004 001 |
| Ordering-No. | Ø 2.5 mm | 66 0011 001 |
| Ordering-No. | Ø 3.6 mm | 66 0012 001 |

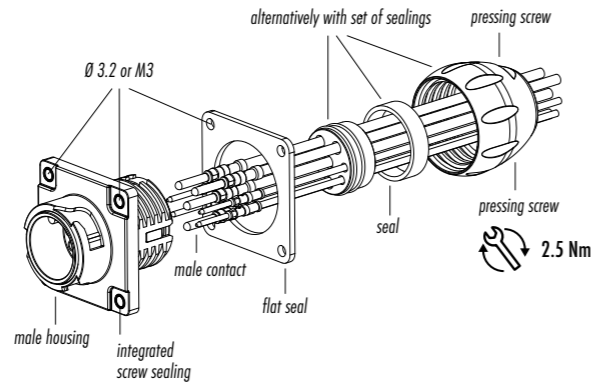

Panel mount connectors 12 contacts

1. Strip single wires to L = 3.5 mm.
 2. Crimp contacts to wires.*
 3. Press crimped contacts into contact carrier until they snap into place.
- Attention!** Bear in mind the positioning of the contacts in relation to the housing.
The positioning of the contacts is stamped on the contact carrier.

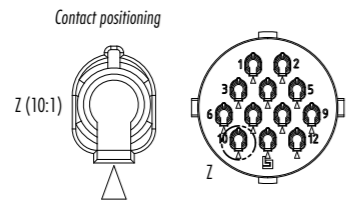

- 3.1. Alternatively when using the single wire seal: **
Pierce through the needed sections of the single wire sealings with a pointed device or tool.
Pass single wires through the seal, strip them off and crimp them to the contacts. Then press contacts (analog to 3.) into the contact carrier, lay the single wire sealings flat onto the contact carrier, press pressure ring to stop and finally fix it with the pressing screw.

Wire-Ø	12 contacts
min.	Ø 1.1 mm
max.	Ø 2.1 mm

4. Push the pressing screw over the bundle of single wires and fix it afterwards by screwing. (recommended torque 1.0 Nm)

- * Crimping tool for single contacts
- | | |
|--------------|-----------------|
| Ordering-No. | 66 0001 014 100 |
|--------------|-----------------|
- Crimping tool for strip contacts
- | | |
|--------------|-----------------|
| Ordering-No. | 67 0001 014 100 |
|--------------|-----------------|
- Extraction tool for contacts
- | | |
|--------------|-------------|
| Ordering-No. | 07 0090 000 |
|--------------|-------------|

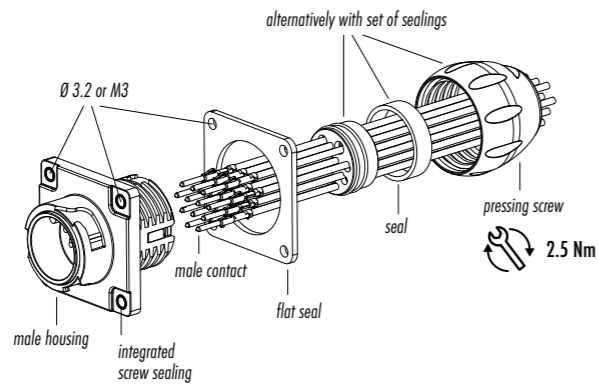

Component part drawing

Panel mount connectors

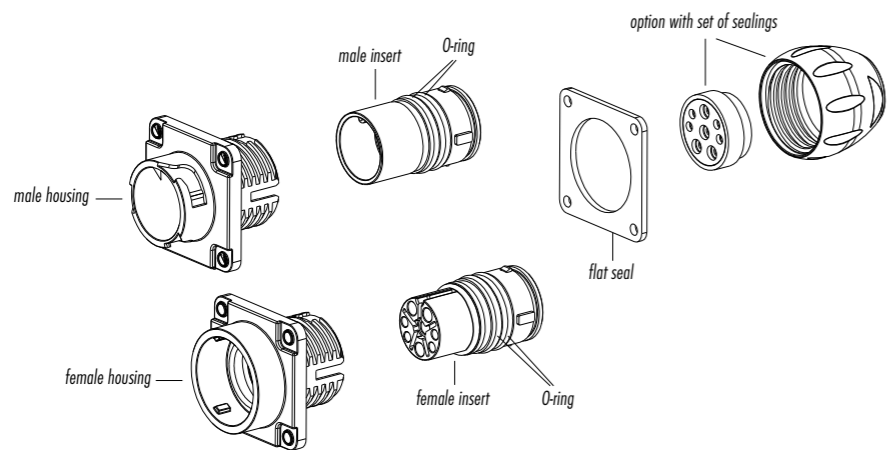

Contact arrangements

Male insert (mating side)

Female insert (mating side)

4+PE contacts

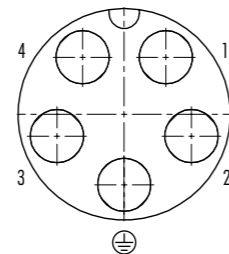
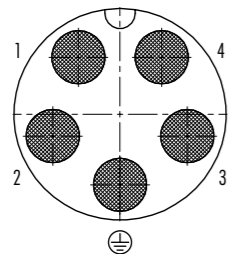

4 + 3+PE contacts

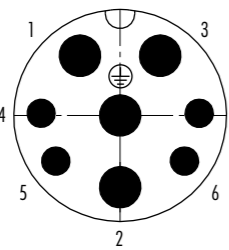

1, 2, 3, ⊕ Ø 2.5 mm
4, 5, 6, 7 Ø 1.6 mm

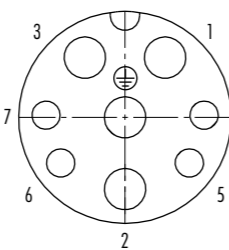

1, 2, 3, ⊕ Ø 2.5 mm
4, 5, 6, 7 Ø 1.6 mm

12 contacts

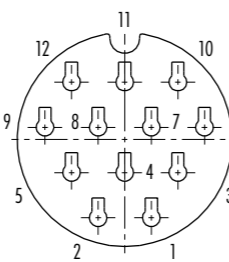
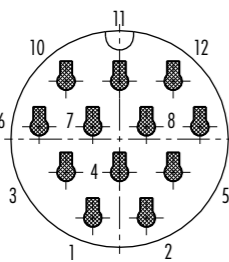

Panel cut out

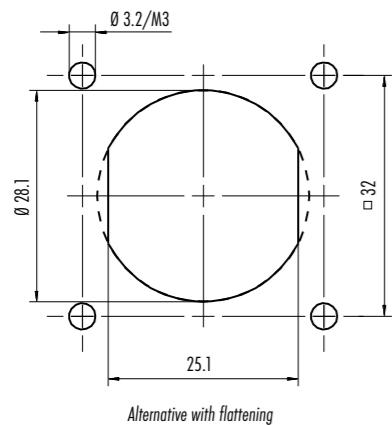

Alternative with flattening

Description

Drawing

Male contact, power, PU 100 pieces, for 4+PE version

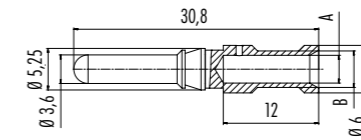

Male contact, power, PU 100 pieces, for 4 + 3+PE version

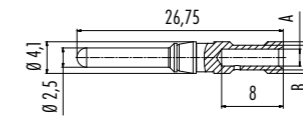

Male contact, signal, PU 100 pieces, for 4 + 3+PE version

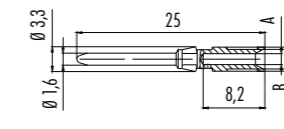

Female contact, power, PU 100 pieces, for 4+PE version

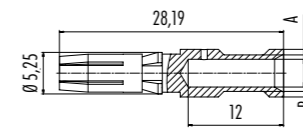

Female contact, power, PU 100 pieces, for 4 + 3+PE version

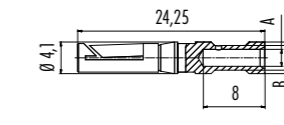

Female contact, signal, PU 100 pieces, for 4 + 3+PE version

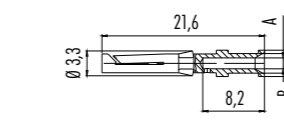

A	B	Wire gauge	AWG	Ordering-No.
2.2	3.3	2.5 mm ²	14	61 1312 139
2.8	3.9	4.0 mm ²	12	61 1310 139
3.5	4.6	6.0 mm ²	10	61 1285 139
1.8	3.0	1.5 mm ²	16	61 0903 139
2.2	3.2	2.5 mm ²	14	61 0902 139
0.9	2.6	0.14 mm ² – 0.34 mm ²	26–22	61 0891 139
1.1	2.6	0.5 mm ²	20	61 0892 139
1.45	2.6	0.75 mm ² – 1.0 mm ²	18	61 0893 139
1.8	3.0	1.5 mm ²	16	61 0894 139
2.2	3.3	2.5 mm ²	14	61 1313 139
2.8	2.6	4.0 mm ²	12	61 1311 139
3.5	4.6	6.0 mm ²	10	61 1286 139
1.8	3.0	1.5 mm ²	16	61 0901 139
2.2	3.2	2.5 mm ²	14	61 0900 139
0.9	2.6	0.14 mm ² – 0.34 mm ²	26–22	61 0896 139
1.1	2.6	0.5 mm ²	20	61 0897 139
1.45	2.6	0.75 mm ² – 1.0 mm ²	18	61 0898 139
1.8	3.0	1.5 mm ²	16	61 0899 139

Single contact (Male), PU 50 pieces,
for 12 pole version



Single contact (Female), PU 50 pieces,
for 12 pole version

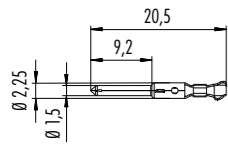

Crimp measures, high dimension (standard value)

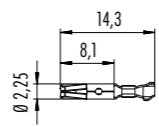
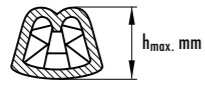

Crimp measures, high dimension (standard value)



Specifications	0.14 mm ² – 0.25 mm ²		0.35 mm ² – 0.5 mm ²		0.75 mm ² – 1.0 mm ²	
Wire gauge mm ²	0.14 mm ² (AWG 26)		0.25 mm ² (AWG 24)		0.35 mm ² (AWG 22)	
Conductor cross section mm ²	0.14 mm ² (AWG 26)	0.25 mm ² (AWG 24)	0.35 mm ² (AWG 22)	0.5 mm ² (AWG 20)	0.75 mm ² (AWG 20-18)	1.0 mm ² (AWG 18-16)
Insulation Ø	Ø 1.0–2.0 mm				Ø 1.6–2.1 mm	
Crimp measures (standard value)	0.9–1.0 mm	0.92–1.09 mm	0.93–1.1 mm	0.95–1.12 mm	1.2–1.33 mm	1.3–1.45 mm
Crimp extraction force acc. to DIN EN 60352-2	24 N	42 N	53 N	73 N	90 N	110 N

Strip contact (Male),
for 12 pole version

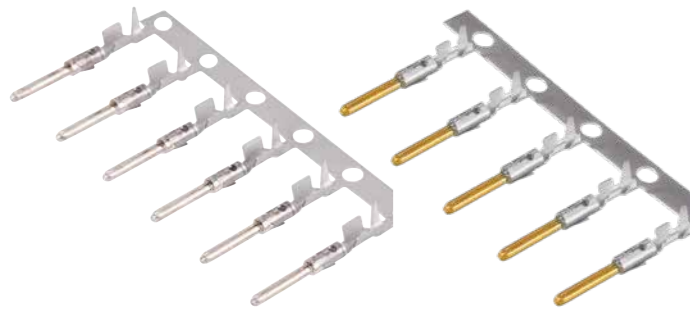

Strip contact (Female),
for 12 pole version

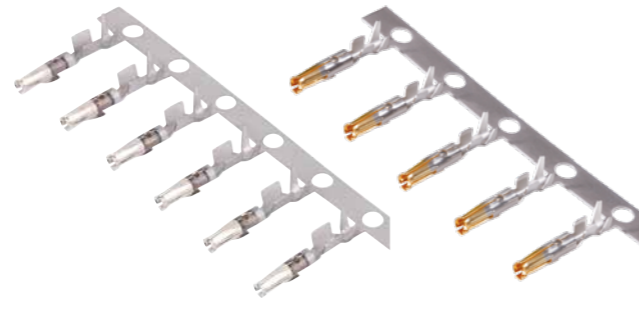

Pin-Ø	Insulating-Ø	WG mm ²	Packaging	Pieces	Silver (ag)	Gold (Au)
1.5 mm	1.0–2.0 mm	0.14–0.25	single	50	61 0799 085 00	61 0799 098 00
			strip	200	65 0799 085 01	65 0799 098 01
			strip	2000	65 0799 085 02	65 0799 098 02
	0.35 – 0.5	single	50	61 0795 085 00	61 0795 098 00	
		strip	200	65 0795 085 01	65 0795 098 01	
		strip	2000	65 0795 085 02	65 0795 098 02	
1.6–2.1 mm	0.75 – 1.0	single	50	61 0796 085 00	61 0796 098 00	
		strip	200	65 0796 085 01	65 0796 098 01	
		strip	2000	65 0796 085 02	65 0796 098 02	

Pin-Ø	Insulating-Ø	WG mm ²	Packaging	Pieces	Silver (ag)	Gold (Au)
1.5 mm	1.0–2.0 mm	0.14–0.25	single	50	61 0800 085 00	61 0800 098 00
			strip	200	65 0800 085 01	65 0800 098 01
			strip	2000	65 0800 085 02	65 0800 098 02
	0.35 – 0.5	single	50	61 0797 085 00	61 0797 098 00	
		strip	200	65 0797 085 01	65 0797 098 01	
		strip	2000	65 0797 085 02	65 0797 098 02	
1.6–2.1 mm	0.75 – 1.0	single	50	61 0798 085 00	61 0798 098 00	
		strip	200	65 0798 085 01	65 0798 098 01	
		strip	2000	65 0798 085 02	65 0798 098 02	

Description	Drawing	Contacts	Ordering-No.
Crimping tool for turned crimp contacts		5	66 0005 000
Crimping tool for stamped single contacts		8	66 0003 001
Crimping tool for strip contacts		12	66 0001 014 100
Extraction tool for turned contacts		12	67 0001 014 100
Extraction tool for stamped crimp contacts		5	66 0012 001
Protective hose fitting for cable connectors		8	66 0004 001 Signal contact
		8	66 0011 001 Power contact
Protective hose fitting, 50 m		12	66 0011 001 Power contact
		4+PE	08 0111 000 000
		4 + 3+PE	08 0111 000 000
		12	08 0111 000 000
		—	08 0071 050 000

Description	Drawing	Contacts	Ordering-No.
Sealing kit, IP67		4+PE	08 3274 000 000 without thrust ring
		4 + 3+PE	08 3111 000 000 with thrust ring
		12	08 3232 000 000 with thrust ring
Protective hose fitting for panel mount connectors		12 4+PE	08 0108 000 000 without thrust ring
		4 + 3+PE	08 0109 000 000 with thrust ring
		12	08 0110 000 000 with thrust ring
Protection cap for male cable connector			08 3107 000 000
Protection cap for female cable connector			08 3108 000 000
Protection cap for male panel mount connector			08 3109 000 000
Protection cap for female panel mount connector			08 3110 000 000

Description	Drawing	Ordering-No.
Cable, PU 100 m		08 3186 000 000 PU 100 m

Specifications of cable	4 (Signal) + 3+PE (Power)	
Wire gauge mm ² ¹⁾	4 x 1.0 mm ² (AWG 18)	4 x 2.5 mm ² (AWG 14)
Material jacket	PUR black	
Insulation wire	PP	
Design of wire (mm)	finely stranded acc. to DIN VDE 0295 class 5	
Cable jacket Ø (mm)	12.3	
Resistance of wire	DIN VDE 0295 class 5	
Temp. range (cable in move)	- 20 °C / + 85 °C	
Temp. range (cable fixed)	- 40 °C / + 85 °C	
Bending radius (cable in move)	7.5 x cable diameter	
Bending radius (cable fixed)	4 x cable diameter	
Approval	UL	

HEC

For the harshest environmental conditions





**Franz Binder GmbH & Co.
Elektrische Bauelemente KG**

Rötelstraße 27
74172 Neckarsulm
Germany

Tel. +49 7132 325-0
Fax +49 7132 325-190

vk@binder-connector.de
www.binder-connector.de

11/2022



Specifications may be changed without notice, errors excepted.

AGB: www.binder-connector.com/en/terms

Ordering-No. W HEC EN 2023

FB082009B1e-01